

## Light Fittings for Fluorescent Lamp

### HRY93 Series Explosion-proof LED Light Fittings for Fluorescent Lamp



- ◆ Explosion protection to
  - CENELEC
  - IEC
  - NEC
- ◆ Can be used in
  - Zone 2
  - Zone 21 and Zone 22
  - Class I, Zone 2
  - Class I, Division 2, Groups A, B, C, D
- ◆ Two enclosure types.
- ◆ Applicable lamp power: 20W, 40W, 60W
- ◆ Built-in LED driver, CC-CV (constant current-constant voltage) output, power factor  $\geq 0.95$ .
- ◆ Main enclosure is extruding formed of copper-free aluminium, anodic-oxidation treatment for surface. Both ends of enclosure are die-casting formed of copper-free aluminium, powder coated surface.

#### Catalogue number logic

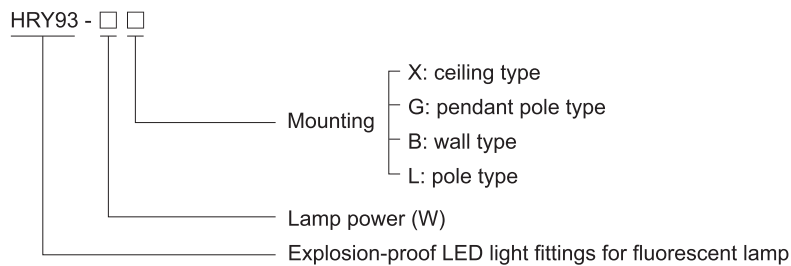

# Zones 2; 21&22

## Light Fittings for Fluorescent Lamp

### HR Y93 Series Explosion-proof LED Light Fittings for Fluorescent Lamp

#### Technical data

#### Explosion-proof LED light fittings for fluorescent lamp HR Y93-□ □

##### Explosion protection

Gas explosion protection

⊕ II 3 G Ex nR IIC T6 Gc

Dust explosion protection

⊕ II 2 D Ex tb IIIC T80°C Db IP66

##### Certificates

ATEX and IECEx (applied for)

##### Conformity to standards

EN 60079-0, EN 60079-15, EN 60079-31

IEC 60079-0, IEC 60079-15, IEC 60079-31

##### Material

Main enclosure

Copper-free aluminium, anodic-oxidation treatment for surface

Both ends of enclosure

Copper-free aluminium, powder coated surface, yellow (RAL1021)

Diffuser

Polycarbonate, corrosion-proof

Exposed fastener

Stainless steel

LED driver

CC-CV (constant current - constant voltage) LED power source, rapid starting, stable performance, power factor  $\geq 0.95$

##### Lamp

Lamp specification

International brand of LED module (supplied with the light fittings)

Lamp power (W)

20W, 40W, 60W

Colour Temperature (CCT)

Cool white: 5400~6500K

Note: cool white is available in general. Warm white (2700~3500K) or nature white (4700~5400K) is optional, please specify when ordering.

##### Rated voltage

220~240V AC 50/60Hz

##### Degree of protection

IP66, IP67(optional)

##### Ambient temperature

-20°C~+55°C

##### Terminal

3 x 1.5~2.5mm<sup>2</sup> (L+N+PE)

##### Mounting

Ceiling type, pendant pole type, wall type, pole type

##### Cable entries

1 x G3/4" cable gland (DQM-I Ex e, plastic)

##### Available cable outer diameter

Φ10~Φ14(mm)

#### Selection table

Type / Ordering code	Lamp power(W)	Weight(kg)	Type / Ordering code	Lamp power(W)	Weight(kg)	Type / Ordering code	Lamp power(W)	Weight(kg)
HR Y93-20 X	20	2.20	HR Y93-40 X	40	2.20	HR Y93-60 X	60	3.40
HR Y93-20 G	20	3.50	HR Y93-40 G	40	3.50	HR Y93-60 G	60	4.70
HR Y93-20 B	20	3.00	HR Y93-40 B	40	3.00	HR Y93-60 B	60	4.20
HR Y93-20 L	20	2.10	HR Y93-40 L	40	2.10	HR Y93-60 L	60	3.30

**Note:** 1. Products above include all the mounting accessories listed in Mounting Accessories & Spare Parts Table (see P2/45).

#### Dimension drawings (all dimensions in mm) - subject to alteration

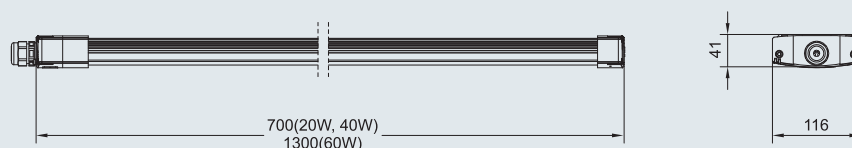

## Light Fittings for Fluorescent Lamp

## HRY93 Series Explosion-proof LED Light Fittings for Fluorescent Lamp

**Photometric data** Note: LED luminous flux is from the standard product of which colour temperature is 5400 to 6500K (cool white).

## HRY93-20□

Rated luminous flux

20W LED: 2000lm

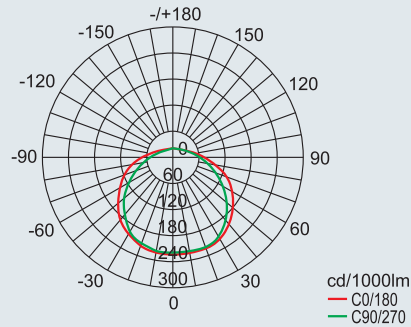

## HRY93-40□

Rated luminous flux

40W LED: 4000lm

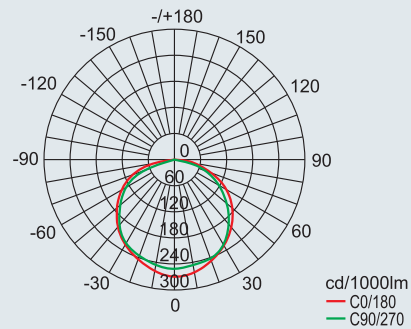

## HRY93-60□

Rated luminous flux

60W LED: 6000lm

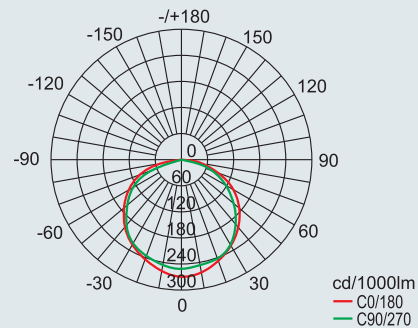

We can provide lighting design and data by professional lighting software DIALUX based upon simulated site situation on request.

## Light Fittings for Fluorescent Lamp

### HR93 Series Explosion-proof LED Light Fittings for Fluorescent Lamp

#### Mounting type (all dimensions in mm) - subject to alteration

Installation reference

X: ceiling type

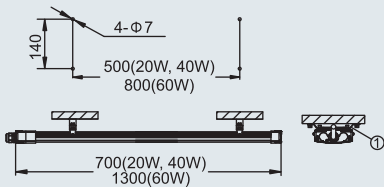

G: pendant pole type

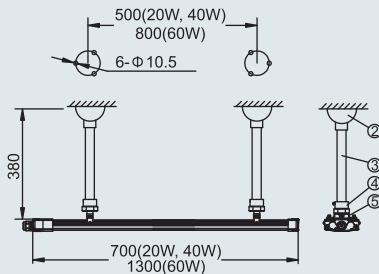

B: wall type

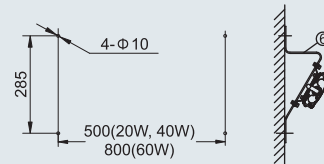

L: pole type (the pole is provided by user)

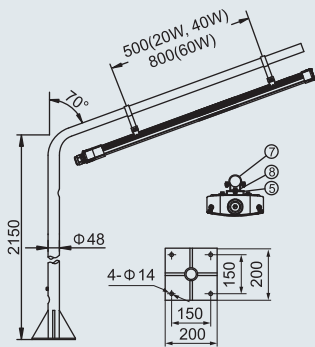

Suitable for ground pole type

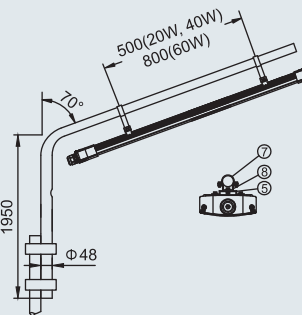

Suitable for fence pole type

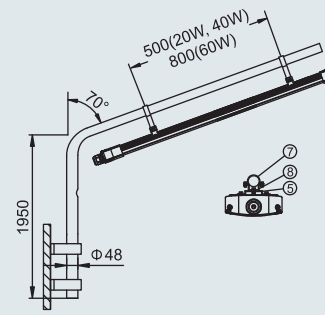

Suitable for wall pole type

#### Mounting Accessories & Spare Parts Table

Supplied according to the mounting type

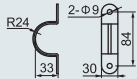
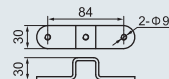
Mounting type	Accessories			Ordering code	Weight (kg)
	Name	Qty	Illustration		
X: ceiling type	① Mounting bracket	2	Q235	85Y01	0.07
	② Sucker	2	See P2/8	5136017	0.15
G: pendant pole type	③ Straight pipe G3/4"	2	Length: 300mm	85Y02	0.41
	④ Coupling	2	Q235	85Y02	0.12
	⑤ Mounting bracket	2	Q235	85Y03	0.07
B: wall type	⑥ Wall bracket	2	Q235	85Y04	0.60
L: pole type	⑦ G1 1/2" Pipe clamp	2		5136014	0.04
	⑧ Mounting bracket	2		5136012	0.04
	⑤ Mounting bracket	2	Same as pendant pole type	85Y03	0.07

**Note:** Accessories not in the table shall be supplied by user.

